



SMARTLIFT®

SL400 RT SKYLIFTER

Technischen daten

Hubkapazität	400 kg
Eigengewicht	360 kg
Saugteller	4 x Ø300 mm
Ladestrom	230V / 110V
Ladedauer	Etwa 4 Std.
Betriebsdauer	Bis zu 8 Std.
Ausgefahrene m	385 mm
Oben / unten	200 mm
Neigung	92° Zurück / 14° vor
Seitliche Verschiebung - Parallel	200 mm
Seitliche Verschiebung - Armen	300 mm
Gieren	44°
Drehung	320°

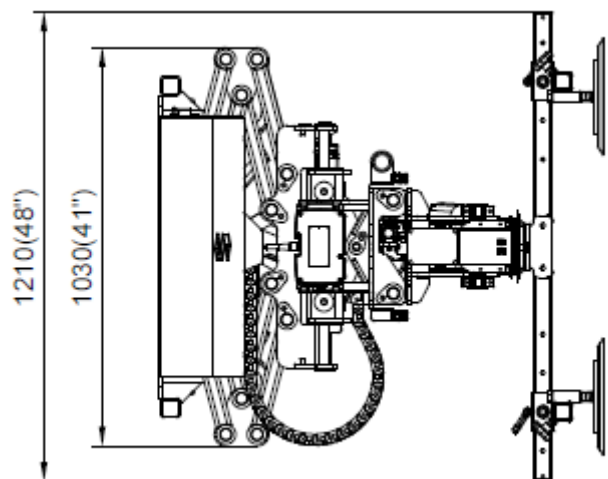
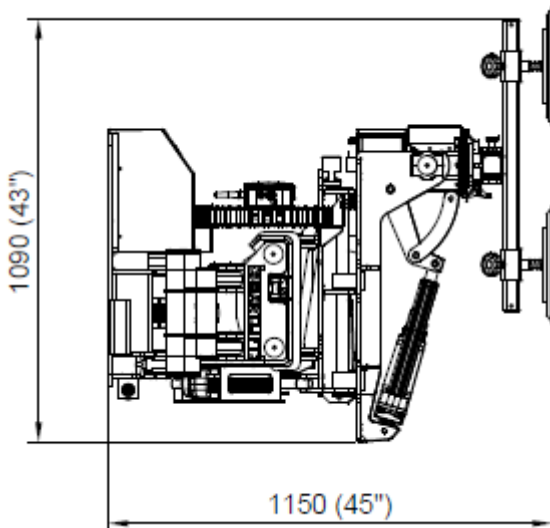
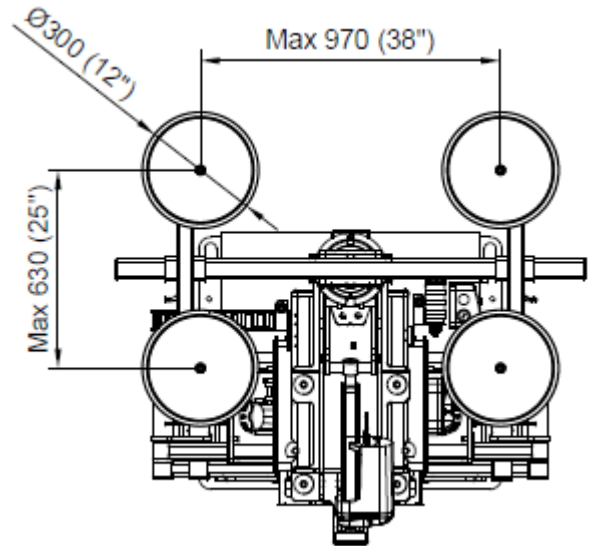



SMARTLIFT®

Ausfahrenem

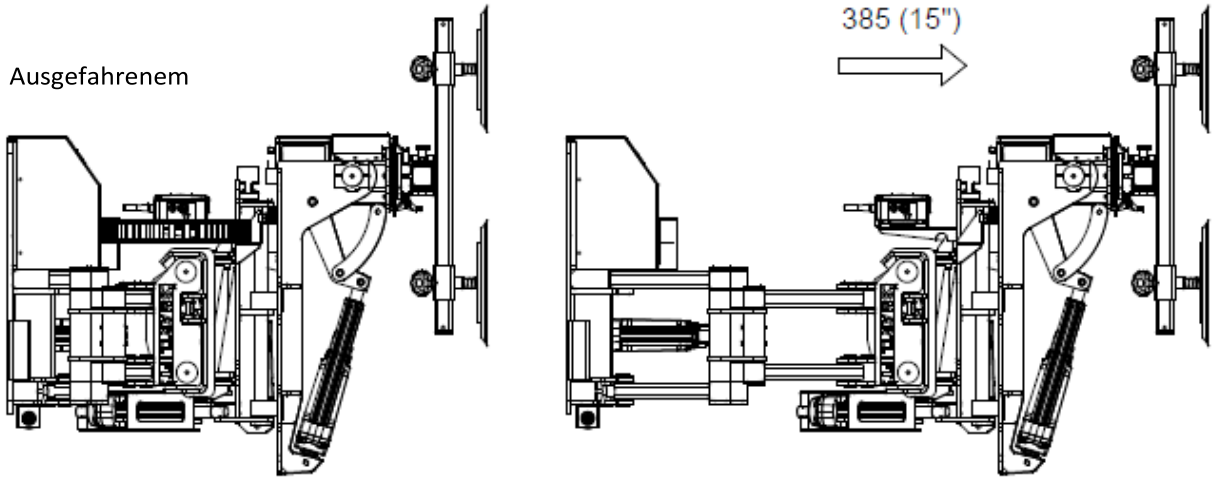

Oben / unten

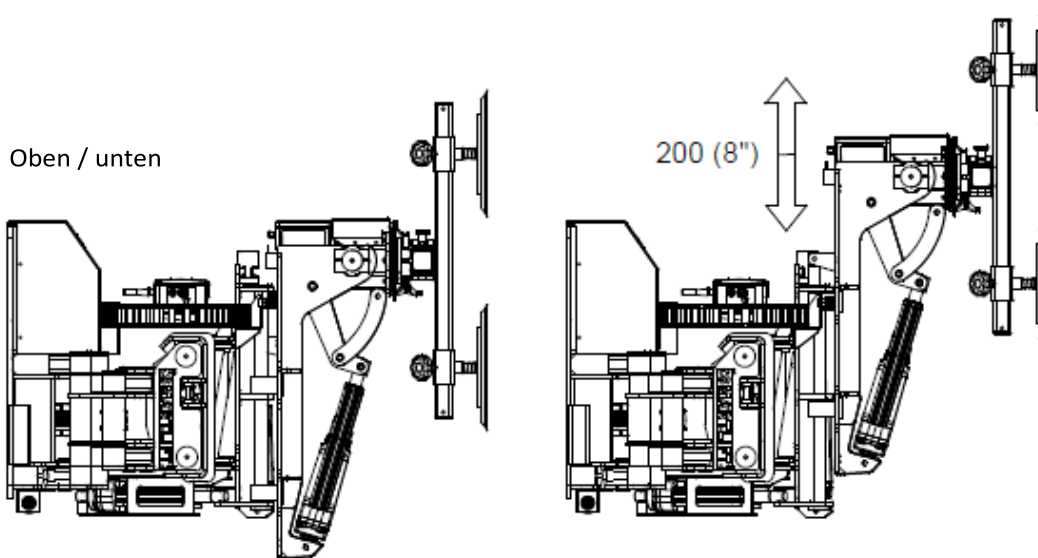

Neigung

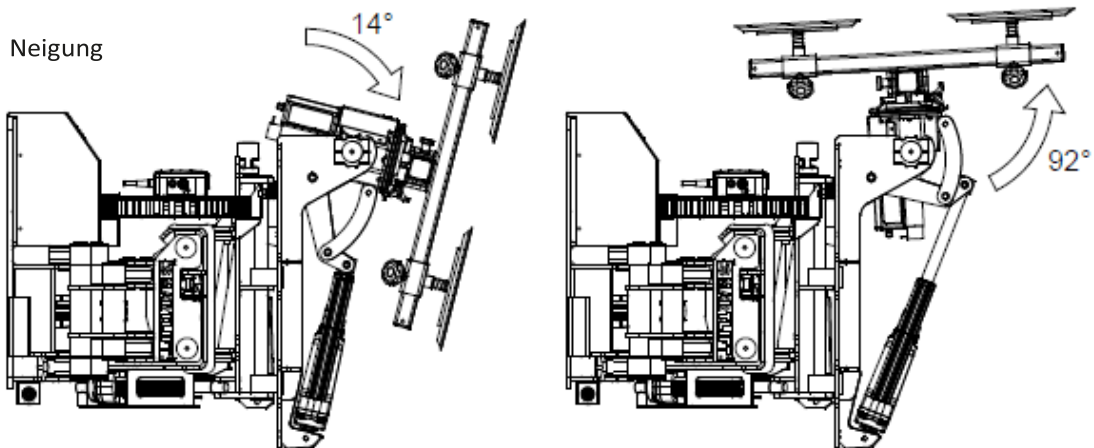



SMARTLIFT®

Seitliche Verschiebung - Parallel

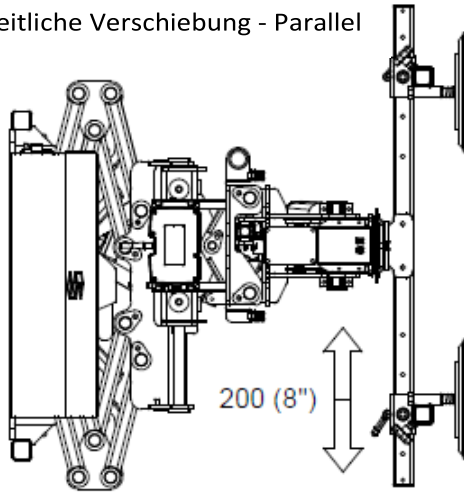

Seitliche Verschiebung - Armen

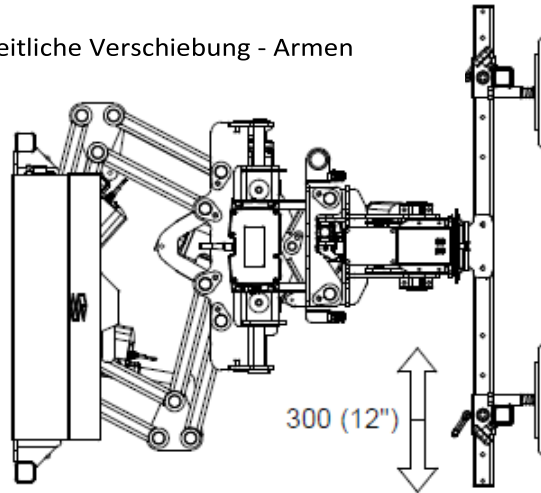

Gieren

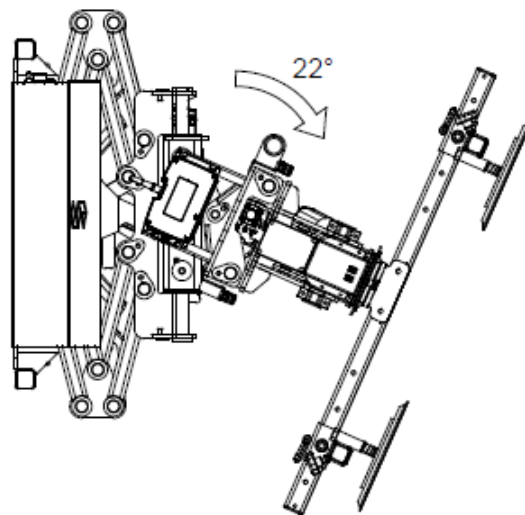
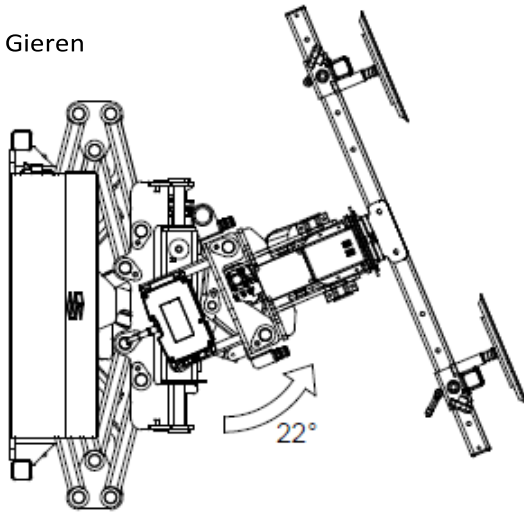

Drehung

